

2017-2018 Geometry Final Exam Review

1. Find x . Round to the nearest hundredth.

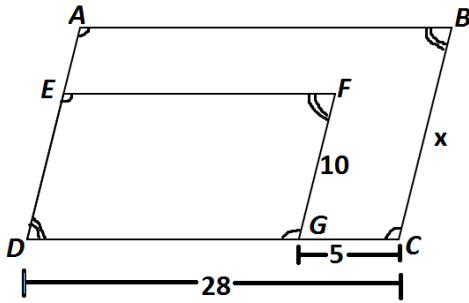

$x =$ _____

2. Find x .

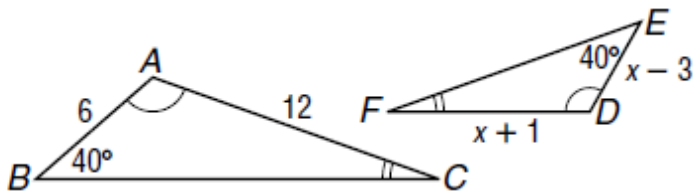

$x =$ _____

3. Given $\Delta STU \sim \Delta PQR$, find x .

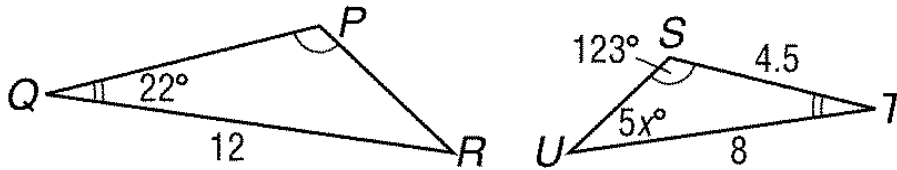

$x =$ _____

4. Given Quadrilateral $HIJG \sim$ Quadrilateral $MNOL$, find x and y .

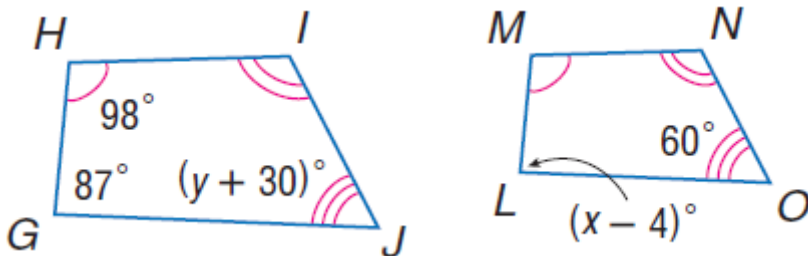

$x =$ _____

$y =$ _____

5. $\triangle ABC \sim \triangle PBQ$. Find $\angle PBQ$ and BQ. Round to the nearest tenth.

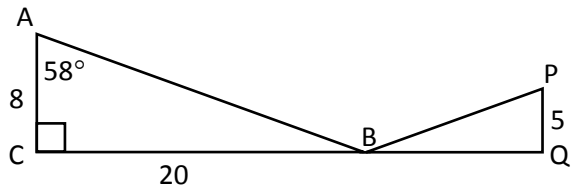

$$\angle PBQ = \underline{\hspace{2cm}}$$

$$BQ = \underline{\hspace{2cm}}$$

6. Triangle EFG is a right triangle with right angle G. Triangle MFN is similar to Triangle EFG. M is on EF and N is on FG. MN is parallel to EG. EG = 9 in, GN = 8 in, NF = 10 in. Draw and label a diagram to model the description of triangles EFG and MFN. Find the measure of MN.

$$MN = \underline{\hspace{2cm}}$$

7. If $\triangle ABC \sim \triangle DEF$, find the perimeter of $\triangle ABC$. What is the ratio of $\triangle ABC$ to $\triangle DEF$?

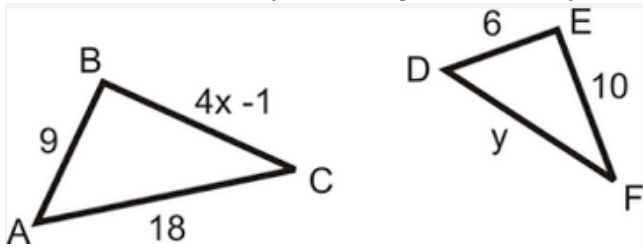

$$\text{Perimeter } \triangle ABC = \underline{\hspace{2cm}}$$

8. Timmy is flying a kite. The length of the string is 37 feet. The kite gets caught on the top of a tree that is perpendicular to the ground. Timmy is 10 feet from the tree's base. How tall is the tree? Round to the nearest tenth.

9. Triangle ABC has side lengths AB = 21, BC = 21 and CA = 42. Is $\triangle ABC$ a right triangle?

10. Find the area of the figure below. Round to the nearest tenth.

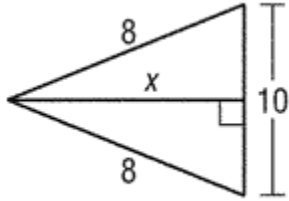

11. Find the exact altitude of an equilateral triangle whose sides are 20 cm long.

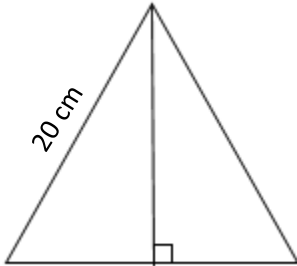

12. If the altitude is $6\sqrt{3}$, what is the perimeter of the equilateral triangle?

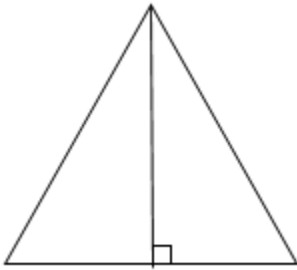

13. Find x and y .

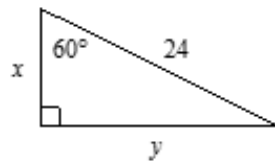

14. Find x and y .

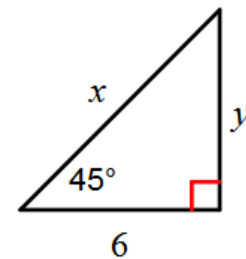

15. Consider the triangle ABC, shown below. Use the Pythagorean Theorem to find the exact value of the missing side. Then find all trig ratios below and simplify all answers.

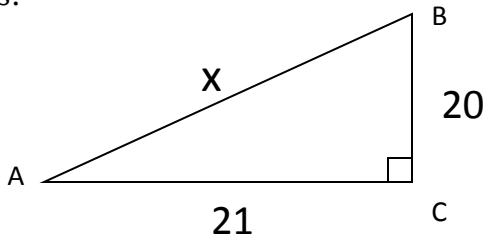

$X =$ _____

$\sin \angle A =$ _____

$\cos \angle A =$ _____

$\tan \angle A =$ _____

$\sin \angle B =$ _____

$\cos \angle B =$ _____

$\tan \angle B =$ _____

16. In the figure, $\tan x = \frac{5}{12}$. Find $\cos x$ and $\sin x$.

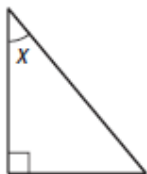

$\cos x =$ _____

$\sin x =$ _____

17. Find the measure of the missing angle. Round to the nearest degree.

a.

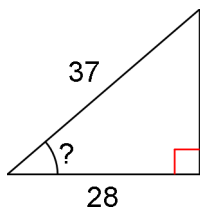

b.

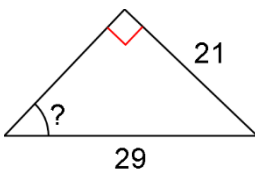

c.

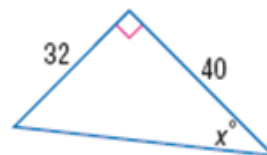

18. Solve to find each missing side. Round to the nearest tenth.

a.

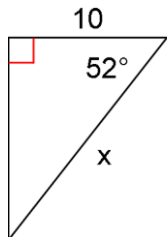

b.

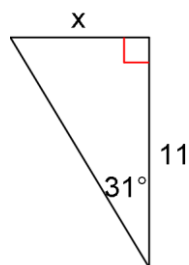

c.

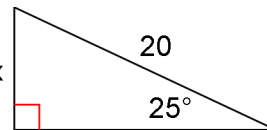

19. An engineer in a lighthouse is looking down at a beacon on a ship's bow. He measures the angle of depression as 25° . The viewing platform in the lighthouse is 30 m above sea level. How far away is the ship from the shore?

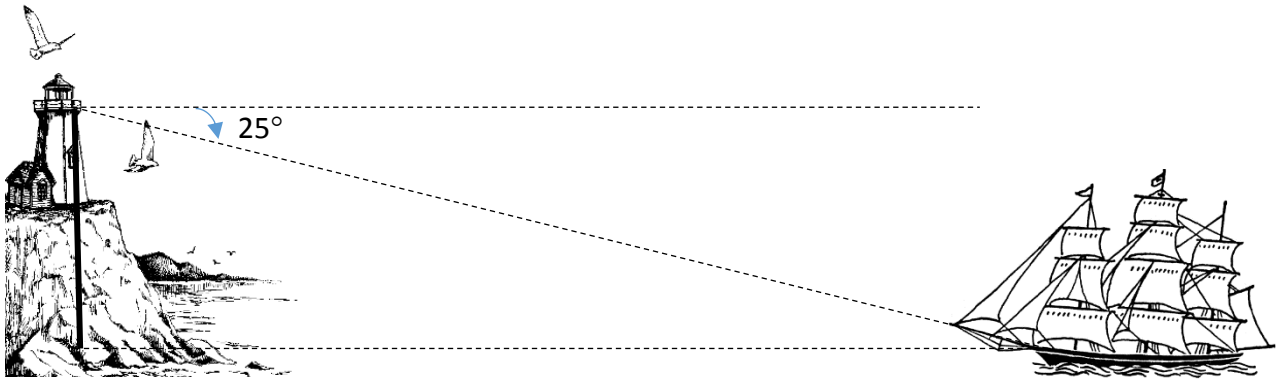

20. Triangle XYZ is a right triangle with right angle Y. $XZ = 15$ and $ZY = 9$. Find $\cos X$.

21. Bob is looking in a mirror to see the top of a flagpole. He is standing 10 feet from the mirror. His eyes are 66 inches above the ground. He uses the following calculations to find the height of the flagpole. Find, describe, and correct his error.

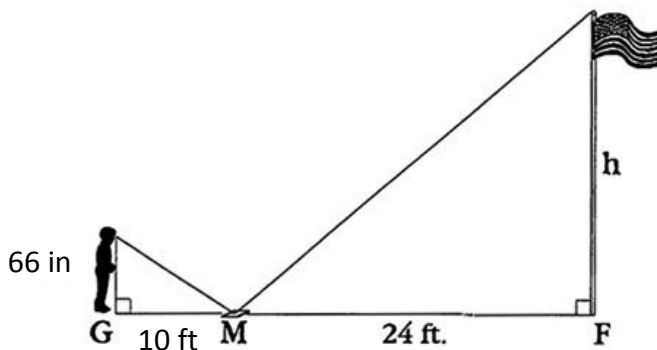

$$\frac{66 \text{ in}}{120 \text{ in}} = \frac{288 \text{ in}}{h}$$

22. Sierra doesn't know why she is not calculating the correct answer for her work. Find, describe, and correct her error.

Find the length of the ramp to the nearest foot.

$$\tan 15^\circ = \frac{2 \text{ ft}}{?}$$

The ramp is 7.5 ft long.

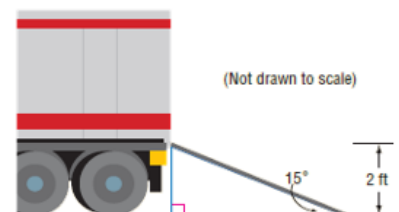

23. Jared read this problem in his textbook: "A six foot tall man casts a 7 foot shadow. A nearby tree casts a 27 foot shadow. Find the height of the tree." There was no picture with the problem in the book. Jared tried to solve this problem, but made a mistake. Find, describe, and correct his error.

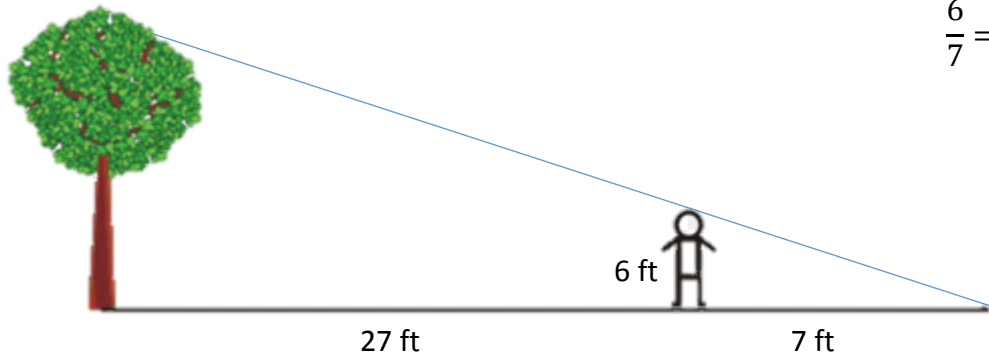

$$\frac{6}{7} = \frac{h}{34}$$

24. Given: EB is a diameter of circle G. True or False? If false, correct the statement to make it true.

- $\angle BGC = 72^\circ$
- $AE \parallel CD$
- $\angle GED = \angle GDC$
- $\angle DGC = 54^\circ$
- $\overline{ED} \cong \overline{AG}$
- $\overline{AE} \cong \overline{CD}$

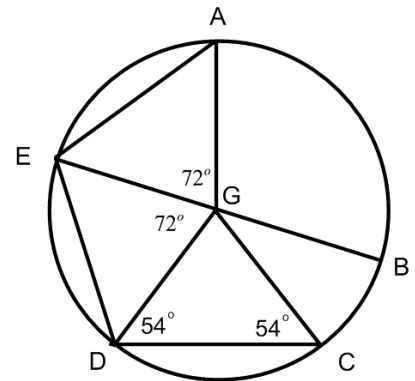

25. Find the length of the segment indicated. Round your answer to the nearest tenth if necessary.

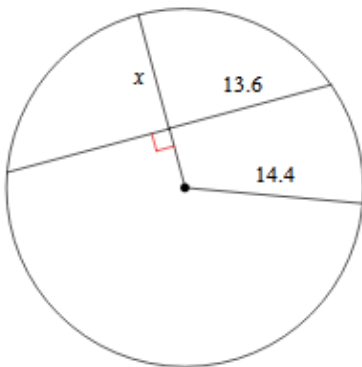

26. In circle R, $CR = RF$, and $ED = 30$ and the radius is 17. Find of RF.

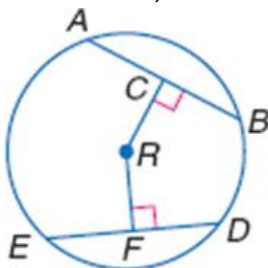

27. Find the perimeter of the polygon. Assume lines which appear to be are tangent.

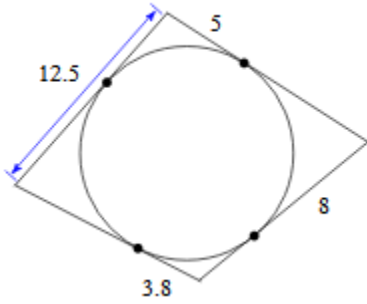

28. The points of a square are $(0, 0)$, $(-8, 0)$, $(-8, 8)$ and $(0, 8)$. Graph the square and write the equation of a circle that would be inscribed in the square.

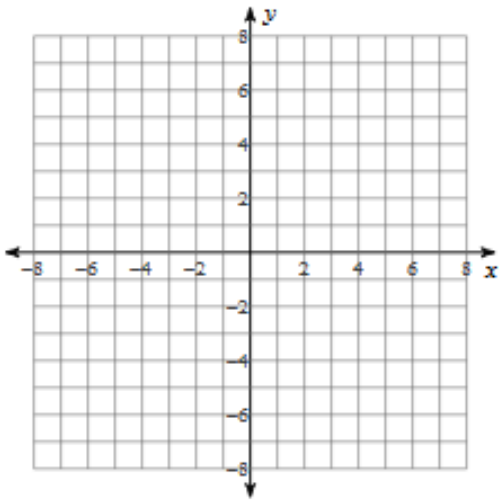

29. A circle is tangent to the triangle at $(3, 4)$. The center of the circle is at $(7, 7)$. Write the equation of the circle.

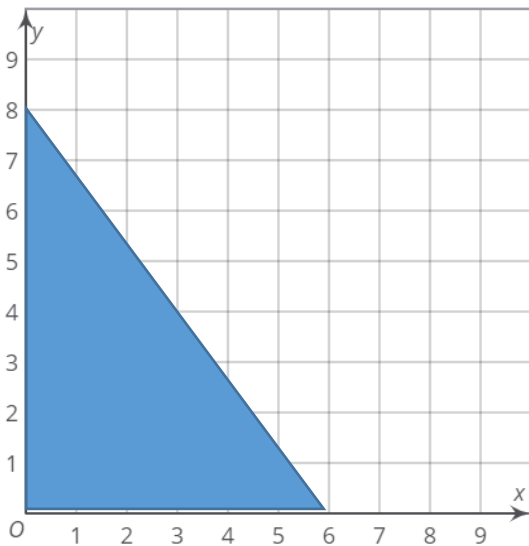

30. What is the area of the circle? Round your answer to the nearest tenth.

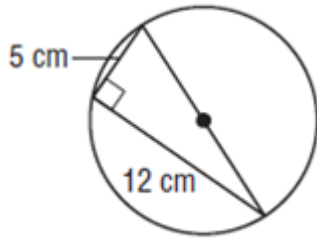

31. Find the exact area of the circle if arc length AB is 10π .

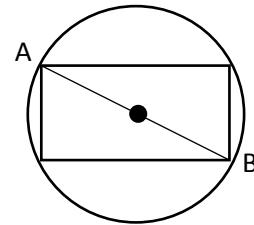

32. If the radius of a circle is 13 m and a central angle is 45° , find the length of the arc defined by the intersection of the central angle and the circle. Write your answer in terms of pi.

33. If the ratio of the circumference of two circles is 4:7, what is the ratio of their radii?

34. The length of arc AC is equal to one-third of the circumference of circle O, and the arc length is 4π meters, find the radius, $m\angle AOC$ and the area of the sector defined by $\angle AOC$ and arc AC to the nearest tenth.

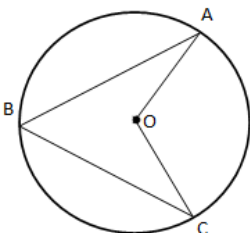

radius = _____
 $m\angle AOC$ = _____
 sector area = _____

35. The $m \angle XZY = 28^\circ$. What is the measure of $\angle XPY$?
 If $XZ = YZ$, what is the measure of \widehat{XZ} ?

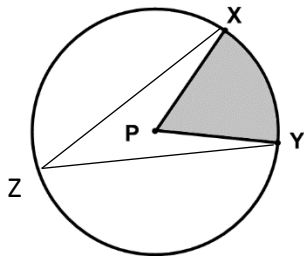

$m \angle XPY = \underline{\hspace{2cm}}$

$m \widehat{XZ} = \underline{\hspace{2cm}}$

Given the coordinates of the vertices, find the area of the figure.

36. $(-1, 1) (1, 7) (3, 1) (1, -5)$

37. $(-2, 2) (2, 4) (2, -6) (-2, -2)$

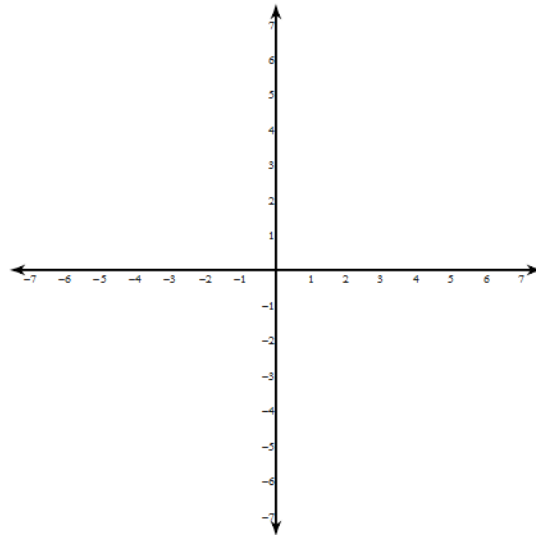
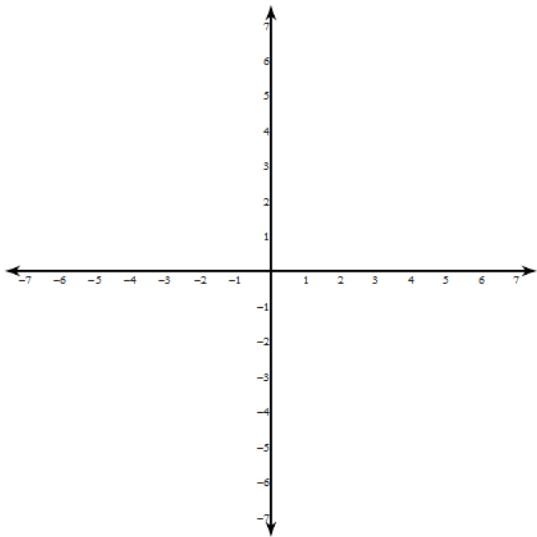

38. Find the area of the shaded region.

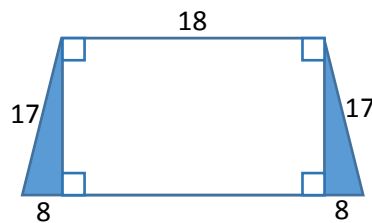

39. Find the area of the circle in terms of pi and the area of the shaded region to the nearest tenth.

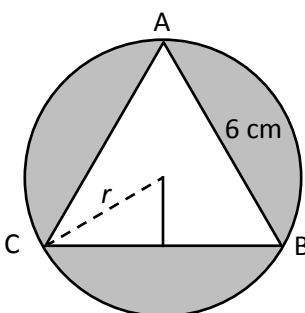

area of the circle: $\underline{\hspace{2cm}}$

area of the shaded region: $\underline{\hspace{2cm}}$

40. The area of the circle is 1156π . Find the area of the shaded region. Round to the nearest tenth.

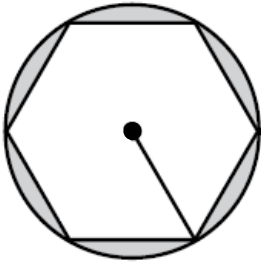

area of the shaded region: _____

41. The diagram represents the top of a bell-tower. The top piece must weigh no more than 100 kg. Aluminum weighs 0.242 kg per square meter. The top piece will include a floor. Determine the weight of the top piece.

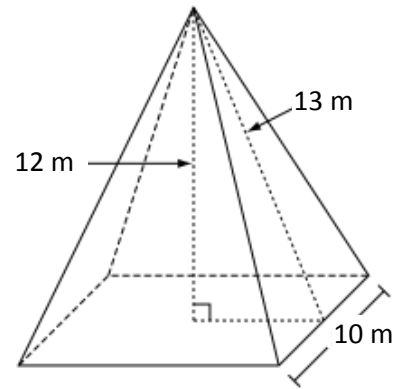

42. Jill wants to have her ottoman, shown below, reupholstered. Find the surface area that will be reupholstered. Do not count the area of the bottom of the ottoman that faces the floor. She has 25 yards of fabric. Show how to determine if she will have enough to cover the ottoman including an extra 10% for waste and seams.

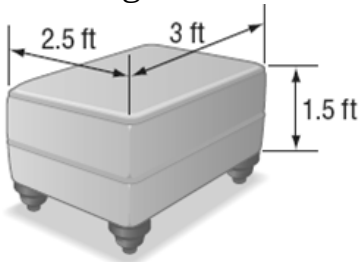

43. A fuel tanker is in the shape of a right cylinder. The full load of the fuel inside will be delivered to two locations; station A will receive one-third of the fuel and station B will receive two-thirds of the fuel. How many gallons of fuel will be delivered to station B? $1 \text{ ft}^3 = 7.5$ gallons. Round to the nearest gallon.

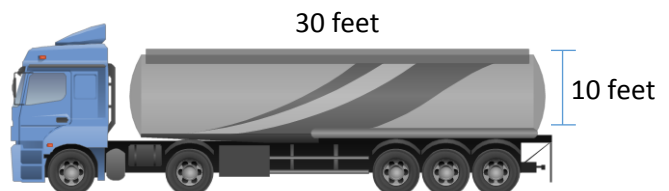

44. Water weighs approximately 62 lbs per cubic foot. The industrial hot water tank has a diameter of 5 feet and a height of 13 feet. When the tank is full, what is the weight of the water inside the tank? Round to the nearest pound.



45. Find the volume of the composite solid. Round your answer to the nearest tenth.

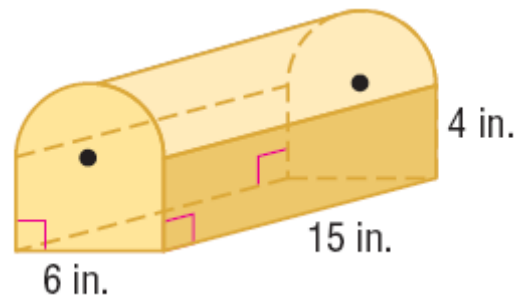

46. College engineering students designed an enlarged external fuel tank of a space shuttle as part of an assignment. The professor liked the design so much, that she decided to have the fuel tank constructed and used. How many cubic meters can the fuel tank hold to the nearest tenth?

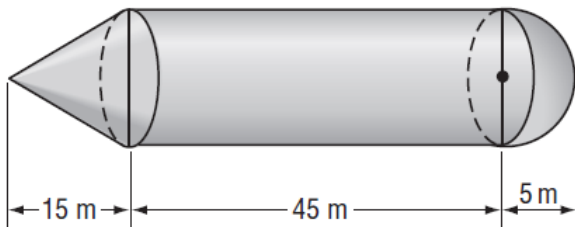

47. The volume of a cone is 460π cm². The cone has a diameter of 20 cm. Find the slant height of the cone.

48. Compare the volume and tell which is greater: A rectangular prism that is 2 inches wide, 6 inches long and 1 inch deep or a square pyramid with a base that is 2 inches per side and is 6 inches high.

49. How many 1 x 1.5 x 2 inch ice “cubes” would be needed to melt into a cylindrical shaped ice bucket and fill it to the top without overflowing? The ice bucket has a diameter of 6 inches and a height of 10 inches. Cubes are whole ice cubes.

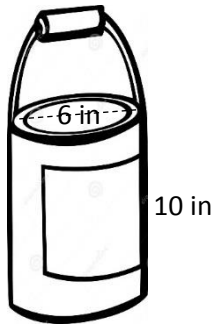

50. A cube has side length 10cm. What is the radius of a sphere with same volume?
51. Identify an angle in Quadrant IV with a reference angle of 30° . Tell the measure of the angle in both degrees and radians.
52. Identify an angle in Quadrant III with a reference angle of 45° . Tell the measure of the angle in both degrees and radians.
53. $\frac{3\pi}{4}$ is an angle whose sine and cosine are opposites. Tell the measure of the other angle whose sine and cosine are opposites in both degrees and radians.

54. If θ is in Quadrant I and $\sin \theta = \frac{1}{2}$, what other angle in a different quadrant will have the same sine?

55. a. If $\angle A$ is in Quadrant I and $\sin A = \frac{1}{2}$, identify $\angle B$ in Quadrant I that has an equivalent cosine in degrees.

b. If $\angle A$ in Quadrant III and $\sin A = -\frac{\sqrt{3}}{2}$, identify $\angle B$ in Quadrant III that has an equivalent cosine in degrees.

c. What is the relationship of $\angle A$ and $\angle B$ when $\sin A = \cos B$?

56. Graph the point $(1, -1)$ in standard position so its terminal side is θ . Then find the reference angle, θ' , and all exact trig ratio values.

$$\theta' = \underline{\hspace{2cm}}$$

$$\sin \theta' = \underline{\hspace{2cm}}$$

$$\cos \theta' = \underline{\hspace{2cm}}$$

$$\tan \theta' = \underline{\hspace{2cm}}$$

57. Identify the point(s) on the unit circle where tangent is undefined.

58. Tell whether sine, cosine, and tangent is positive or negative in each quadrant.

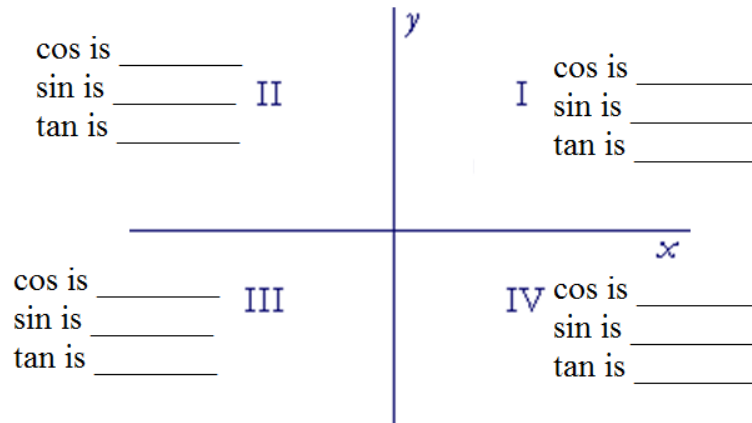

Give the exact measurements for the following.

59. $\cos -45^\circ$

60. $\tan 210^\circ$

61. $\cos 510^\circ$